

Centrifugal Compressors

**Custom build
Solutions for Complex
Requirements**

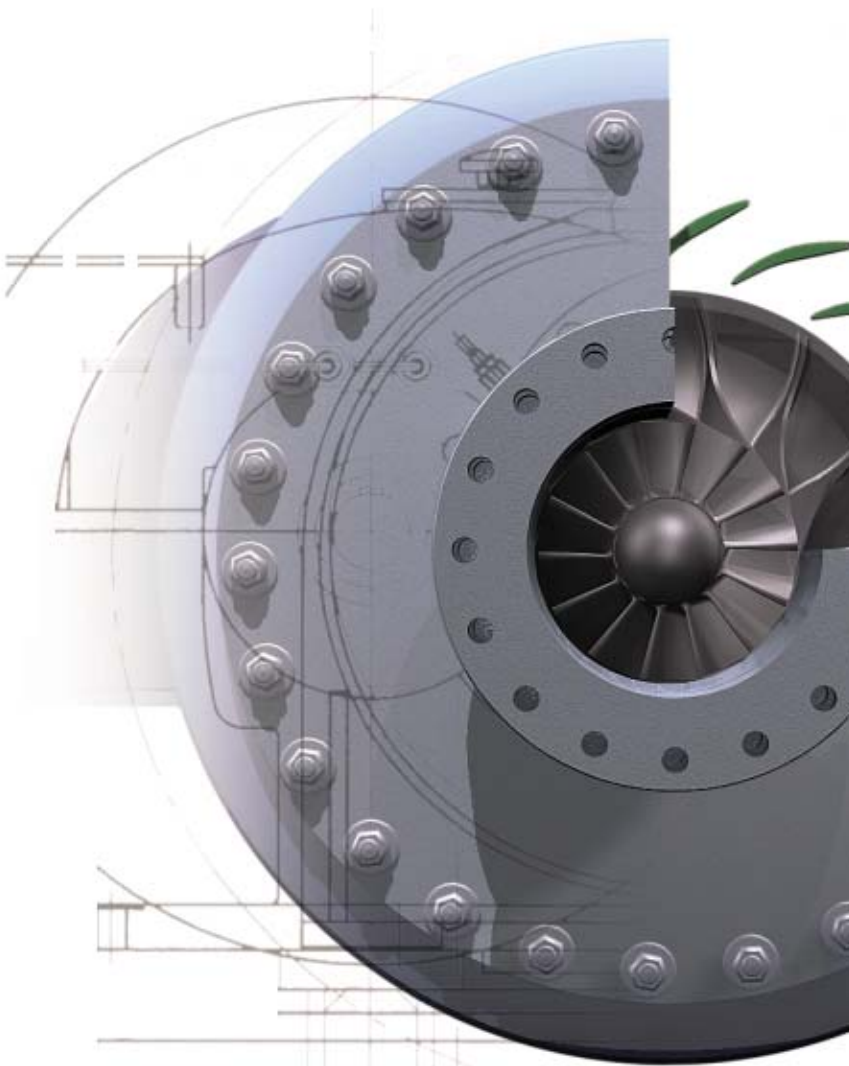

**Smart Centrifugal
Compressors – Economical
and Powerful.**



A broad variety of industrial applications require compressed industrial gases in their process plants.

Predominantly, this applies to applications in the fields of chemistry, petrochemistry, bulk pharmaceutical and food industry. Not only the reliable and efficient functionality of the centrifugal compressors are the main decision criteria, but also the requirement for oil and particle free industrial gases.

FIMA centrifugal compressors definitely meet all aspects of the requirements mentioned above.

For many years **FIMA** has been developing and supplying centrifugal compressors for technically challenging opportunities. Besides our continuous R&D efforts and our long-standing experience, our key to success is our openness to tackle and to solve new sophisticated problems together with our clients. Specific customer requirements, branch related regulations and specific industrial standards are taken into account when designing **FIMA** machines. An important contribution to operational reliability may be provided by the integration of the compressor controls into the process control and monitoring system used by the customer.





Benefits:

-  **Low capital expenditure and minimized TCO costs**

-  **Minimized energy consumption**

-  **High operational reliability**

-  **Minimized downtimes**

-  **Single sourcing**

-  **Custom-built solutions by modular design**

-  **Reduced floor space**



Technical description:

Centrifugal compressors are fluid flow engines, which convert kinetic energy into an increase of the pressure of the gas. Compared to our typical radial blowers the

tip speed and rotational speed of our centrifugal compressors is significantly higher as a result of the required increased differential pressure. Therefore, single stage gears are widely used, which are designed in accordance with the maximum loads which are expected during operation. An integrated oil system guarantees the required pressure oil lubrication. In order to meet the requirements and

conditions of each application the various components of our centrifugal compressors are carefully selected from case to case.

The geometry of the impeller, diffuser and casing is calculated and optimized with respect to the aerodynamic laws. The various operating conditions are achieved either by adjustable flow controllers or by frequency converters.

Based on the operational parameters the appropriate sealing concept of our centrifugal compressors is selected. Same principle applies to the instrumentation and control system, which additionally to the controlling and monitoring of the **FIMA** centrifugal compressor also guarantees the controlled shut down in case of any emergency.

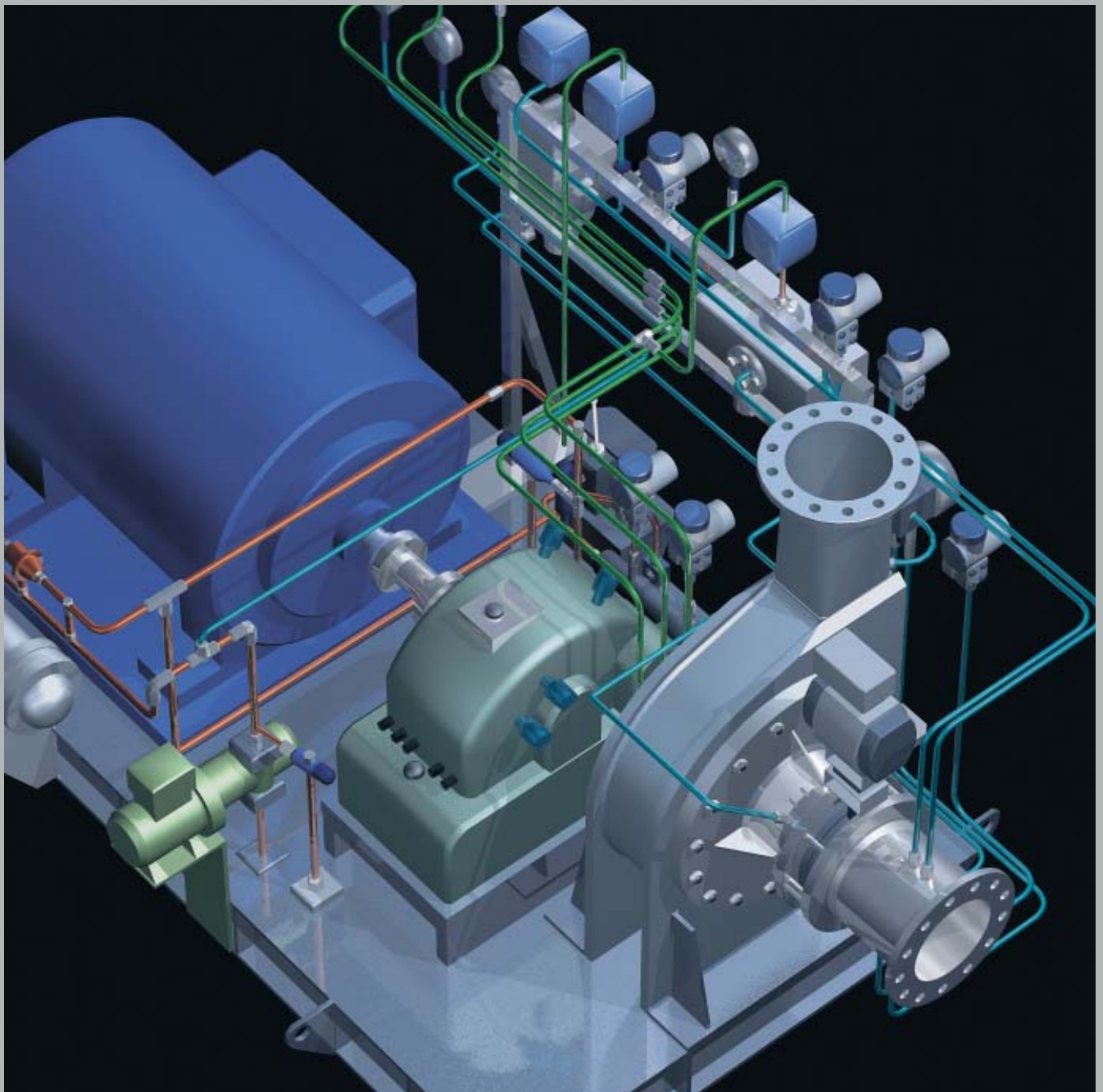

In **FIMA** centrifugal compressors the shaft seal is designed as an interchangeable component which allows to use the appropriate sealing concept for each application.

The proven and tested **FIMA** turbo labyrinth seal is our standard and with its modular design it can be easily adapted to the various requirements. In case of superior requisitions concerning the tightness, mechanical seals from the leading European manufacturers are available such as the single self-lubricating type or double or tandem types with barrier gas supply. Both, the **FIMA** turbo labyrinth seals and the mechanical seals offer superior operational reliability and minimized wear as well as reduced maintenance expenses.

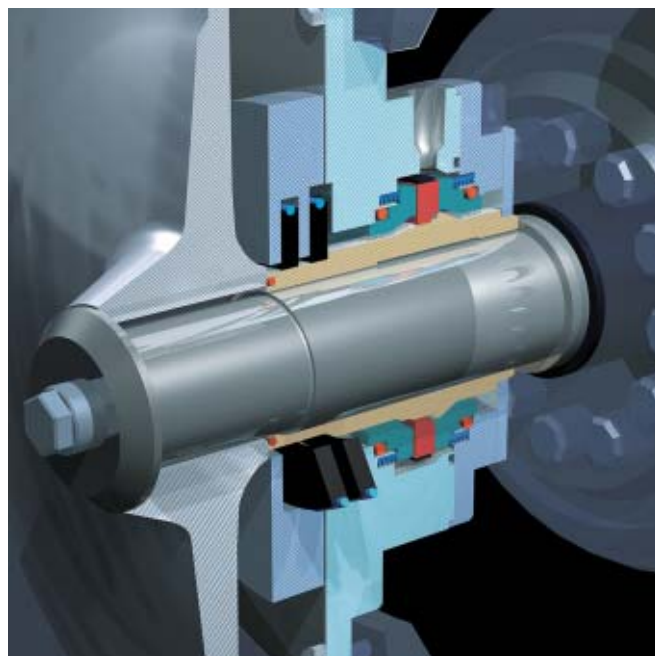

Predominantly, casing and impeller of **FIMA** centrifugal compressors are of welded design which allows a high flexibility in terms of material selection and of material combination. Highly stressed impellers running with tip speeds up to 400 m/s (80,000 ft/min) are cut from the solid block. All our impellers are tailor-made and designed and manufactured according to the specific requirements of each application and, hence, offer superior efficiencies within a broad operating range.

Various designs of modern TURBO-impellers with three-dimensional blade contour of backward or radial ending, open or covered are available.

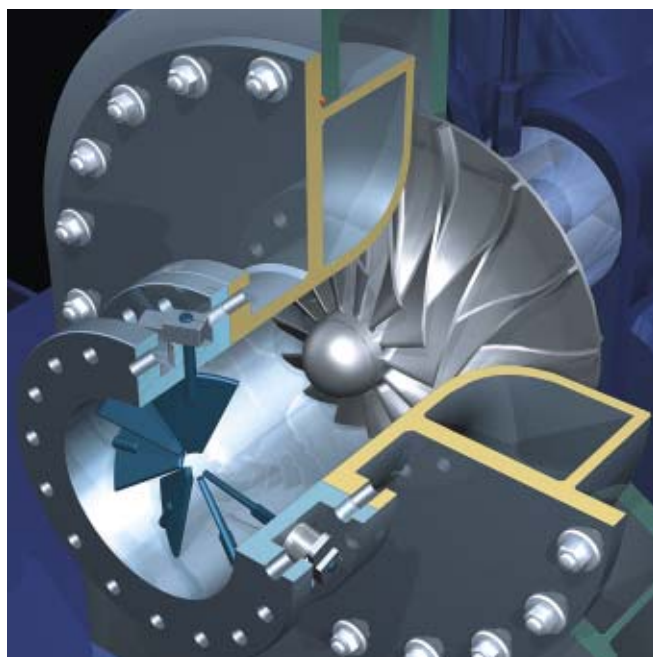
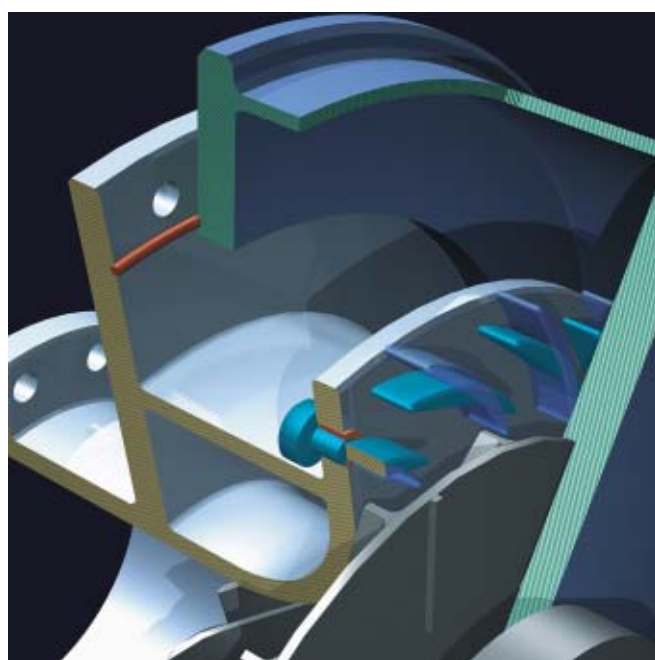

Adjustable flow controllers allow the adaptation of the flow rate according to the specific requirements which also guarantees the economical and efficient operation in the part-load range.

Flow controllers are either inlet guide vanes located upstream of the centrifugal compressor or adjustable diffusers located downstream depending on the application.

The combination of both shifts the surge point to even lower flow rates and, thus, extends the operating range of the **FIMA** centrifugal compressor.

For **FIMA** centrifugal compressors the standard oil system is integrated in the base frame. All parts such as oil pumps, cooling units and filter elements as well as the instrumentation is clearly arranged on the base frame. Main advantages of this concept are the compact design and the delivery as a plug-and-play unit.

Of course, on customer request we also supply centrifugal compressors with oil systems which are installed separately to the compressor unit.

FIMA exclusively uses well-proven and high quality parts for the oil system.

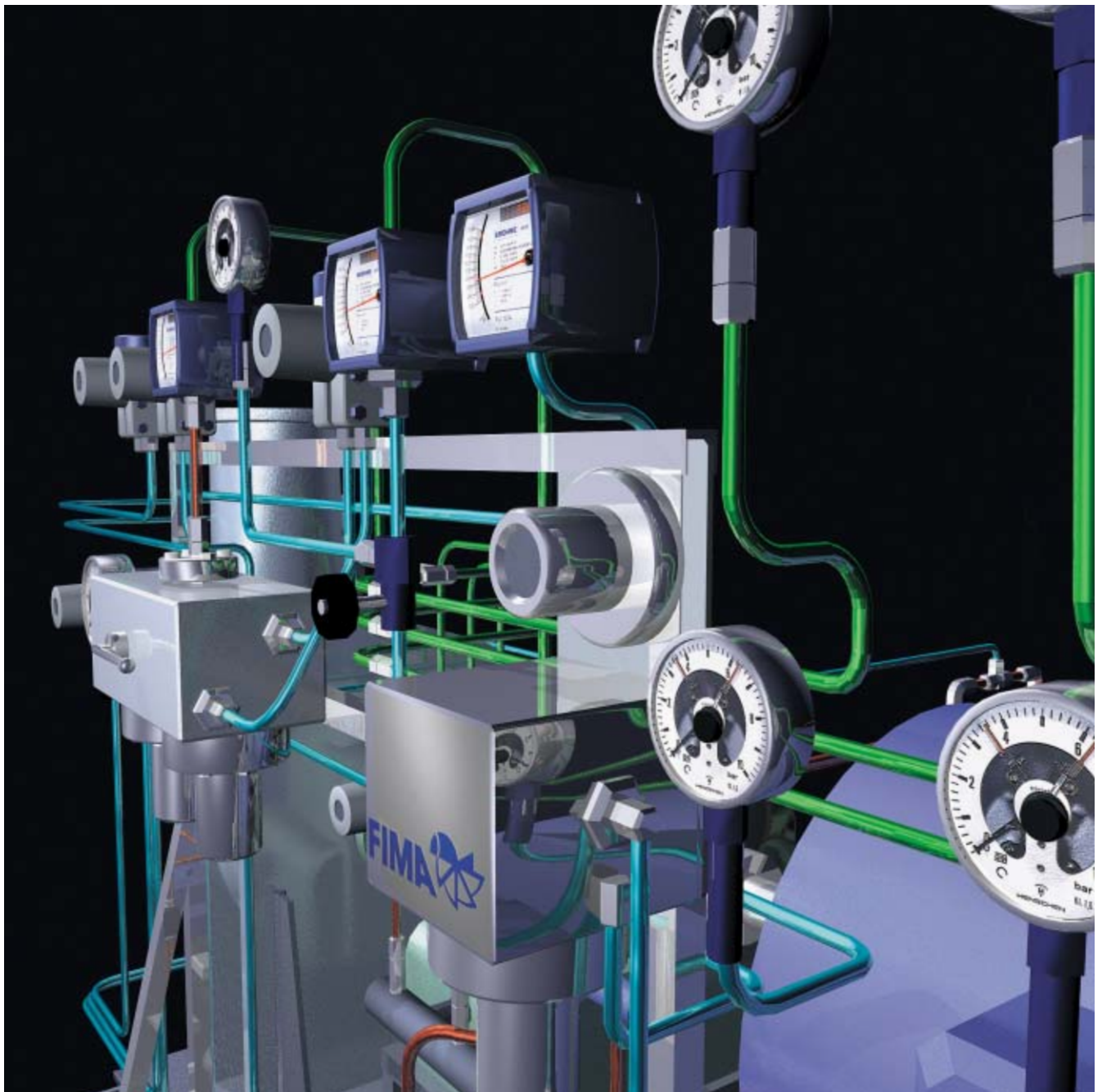

In the basic version the drive unit for **FIMA** compressors consists of motor, coupling and gear. When following the API 617 guide lines an additional high speed bearing unit is used for driving the impeller. The gear is designed, manufactured and tested according to DIN 3990 resp. AGMA. The tilting pad bearings used for the pinion shaft offer decisive advantages compared to roller bearings and minimize the down times of the centrifugal compressor. The lubrication is provided with a pressure oil system. For higher power requirements the use of a turbine instead of an electric motor may be considered.



Scope of supply:

Features such as intake filter elements, downstream coolers, silencers, bypass or blow-out valves as well as additional instruments guarantee the best solution for each application. In order to cut down the assembly times, **FIMA** delivers its centrifugal compressors as plug-and-play units which are thoroughly tested before being shipped.



With the help of a modularly designed data acquisition system the control system monitors all relevant operational parameters and ensures that the centrifugal compressor is operated at optimized operating and process engineering conditions. Generally the data and information is displayed on a line display. Optionally, **FIMA** offers visualisation and data filing modules for the entire compressor unit which enables the operator to constantly track all process parameters on the colour display and to record them as they change over time. The selection of the control system and its implementation in an existing DCS system always results from the close co-operation with the customer.

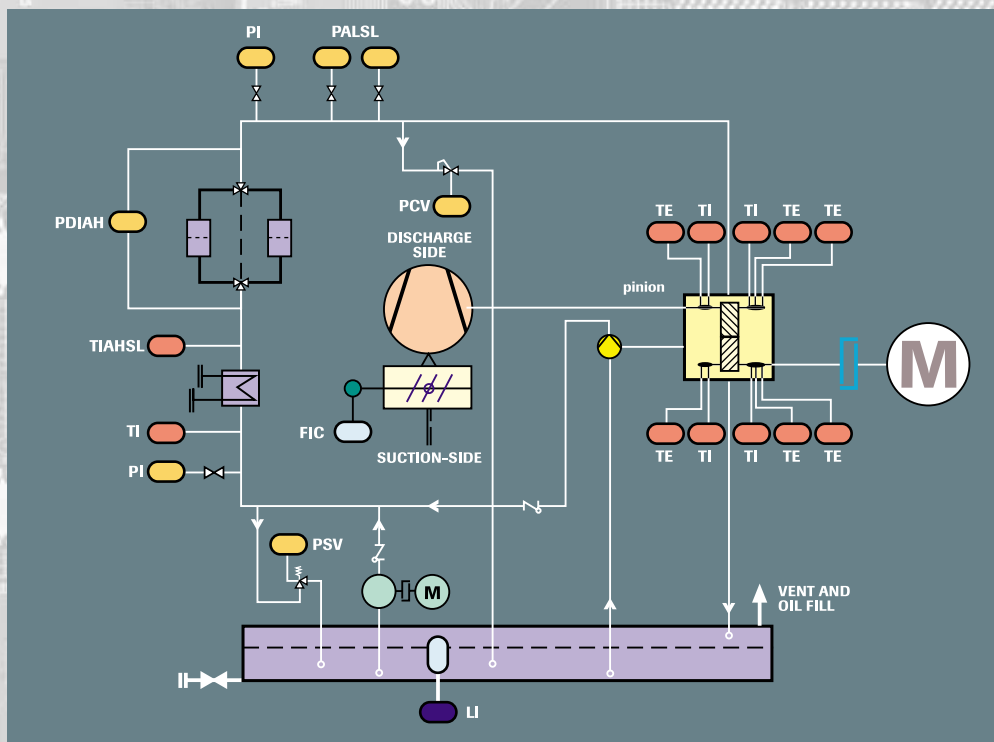

The FIMA System – Modular Interchangeable Components



All components are developed in order to meet the mostly severe requirements of the process industry. Both, the mechanical and the aerodynamic design result from decades of internal R&D work and a constant exchange of experience with our clients.

Every **FIMA** centrifugal compressor has to pass a final test procedure before being delivered; the scope of this

test is specified in a project related quality plan. In either case, our centrifugal compressors perform a dry run including the test of the functionality of the entire system, the performance test and the check on the vibration characteristics. Further tests are possible on request. The results are documented and filed in comprehensive test reports.

FIMA looks back on more than 50 years of engineering tradition as well as many years of experience in the processing of special high-quality materials. Highly qualified staff combined with team experience are an important requirement for the reliability and quality of our products – from the industrial fan to the centrifuge dryer.

You are cordially invited to come to our idyllic country side home, in order to get an impression of our company, our staff and our first class products.

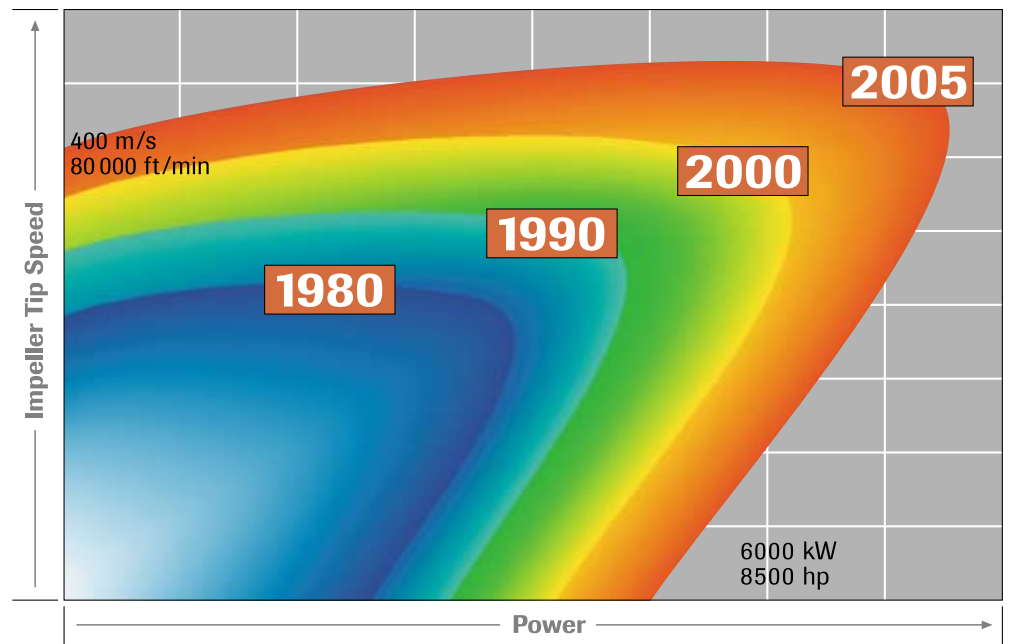

FIMA
Maschinenbau GmbH
Fluid Flow Technology Department

Oberfischach
Oberfischacher Straße 58
D 74423 Obersontheim

Phone +49 7973 693-0
Fax +49 7973 693-110
E-Mail info@fima.de
www.fima.de

